

Aquatec 6800/8800 Series

Still the global standard in booster pump technology, providing reliable inlet pressure for efficient membrane utilization. These pumps are capable of continuous duty and are just as effective for recirculation based applications.

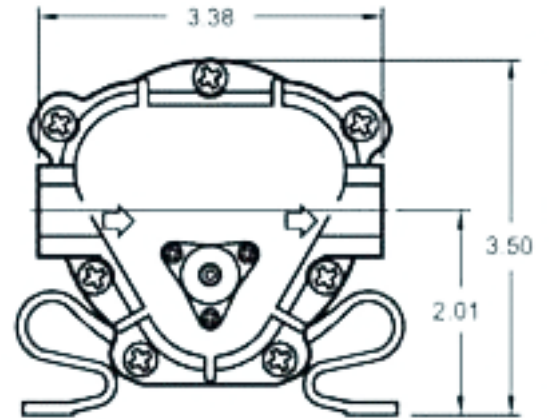

Typical Applications

- + Water treatment
- + Reverse osmosis
- + Medical labwater
- + Carbonation systems
- + Laser cooling systems
- + Misting systems
- + Fuel cell
- + Alternative energy / solar

These pumps are ideally suited to work with hydro-pneumatic storage systems, but are also compatible with most hydraulic shut-off valves.

These pumps are commonly used with one or more flow control components including: tank shut-off / pressure switch (PSW Series), tank level controller (TLC Series) or an electronic shut-off valve (ESO Series).

A typical "R.O. Kit" would include a booster pump, pressure switch, and a transformer. All system components are sold separately.

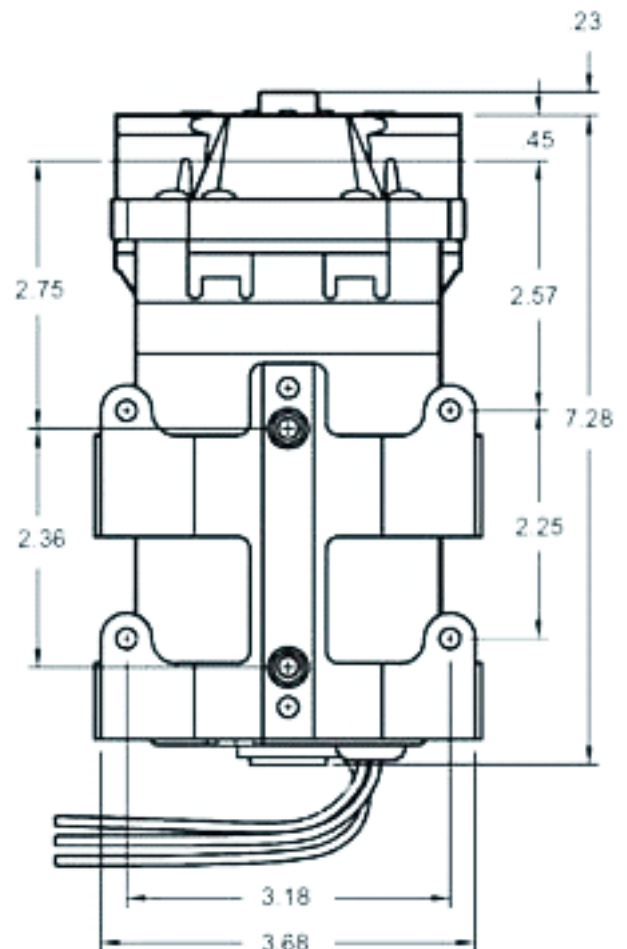

Technical Specifications

Motor:

24 VAC, permanent magnet. Totally enclosed, non-ventilated. Leads are 20AWG, 6" long. This motor is not equipped with thermal protection. For user safety, optimal performance and maximum motor life, the motor surface temperature should not exceed 150°F (66°C).

Envelope Dimensions:

Approximately 75mm x 100mm x 175mm, weighing 2.7 Kg.

Mounting:

Aquatec's patented "flex-mount" baseplate significantly dampens vibration and reduces noise. Other steel mounting baseplates and universal baseplates are available at no additional cost. Pump performance may be affected by location and positioning.

Control Options:

Internal Bypass (20-200 PSI) .

Fittings:

Available options include built-in 3/8", 1/4", or 5/16" John Guest half cartridges.

Pump design:

3 chamber diaphragm pump, self priming, capable of being run dry.

Materials:

Housings: Nylon
Valves: EPDM
Diaphragm: Santoprene
Fasteners: Stainless steel

Liquid temperature: 170°F (77°C) max.

Pump certifications: NSF Standard 58.

Priming capabilities:

Model 68X0: 3 feet
Model 68X1: 4 feet

Performance Data

Discharge pressure (PSI)	Pumphead model				Recommended by-pass pressure	
	68X0		68X1		PSI	Code
	Flow (LPM)	Current (Amps)	Flow (LPM)	Current (Amps)		
80	0.38	0.62	0.45	0.72	110	J
70	0.41	0.58	0.50	0.67	100	I
60	0.43	0.53	0.58	0.61	90	H
50	0.49	0.49	0.61	0.56	80	G
40	0.55	0.43	0.63	0.49	70	F
30	0.59	0.38	0.66	0.43	60	E
20	0.63	0.33	0.70	0.36	50	D
10	0.67	0.27	0.77	0.28	40	B
Open	0.73	0.23	0.84	0.23	30	A

Performance measured with flooded inlet (0 PSI), 70°F (21°C) ambient water temperature and voltage controlled at 24v AC. Positive inlet pressure will increase the discharge pressure by a similar amount for a given flow. Maximum inlet pressure is 60 PSI.